

D2.2 – Train – FCHPP interface. Block schematic

WP 2 – FC powered Train Demonstrator, Architecture and Concept

Task 2.2 – Interface definition Train-FC Hybrid Powerpack

Author	Sergio Gascón, CAF
Phone number, E-Mail	+34 676 59 72 41, sgascon@caf.net
Date	22.11.2021
Document Status	X Draft prepared for final review within task / WP
	X Finalised draft document at Task / WP level
	X Document after quality check
	X Document approved by SC
	X Document approved by TMT
	X Document submitted to FCH-JU

Dissemination Level

PU: Public X

CO: Confidential, only for members of the consortium (including the Commission Services):

Document Status History

Status Description	Date	Partner	Status Code in Filename
Draft prepared for final review within task	22.11.2021	Sergio Gascón, CAF	Draft_final_review_task
Finalised draft document at WP level	30.11.2021	Sergio Gascón, CAF	WP_final_draft
Document after quality check	02.12.2021	Thomas Landtmeters, TME	QC
Document approved by SC	27.12.2021	SC	Approved_SC
Document approved by TMT	27.12.2021	TMT	Approved_TMT
Document submitted to FCH-JU	27.12.2021	DLR	Submitted

Contributions Table

Partner	Contribution
CAF	Interface definition of generic Train-Hybrid PowerPack (electric, mechanic, fluidic, thermal, monitoring and control, ...)
DLR	Support / check specification of the train prototype
TME	Definition of responsibilities for interface areas between Toyota Fuel Cells and Train. Provide requirements for H2 Supply System (Hydrogen quality, mass flow, medium pressure). Provide communication protocol for FC module control. Provide data and requirements for the Cooling System of a FC System
RENFE	Support and check the design of interfaces of the new systems and functions of the train in the project
CNH	FCHPP view: hydrogen system requirements, pipes, sensors, safety. Provide information about the interfaces with the hydrogen refilling station. Review of the P&ID.

This project has received funding from the Fuel Cells and Hydrogen 2 Joint Undertaking under grant agreement No. 101006633. This Joint Undertaking receives support from the European Union's Horizon 2020 research and innovation programme, Hydrogen Europe and Hydrogen Europe research.

Executive Summary

The project 'Fuel Cell Hybrid Power Pack for Rail Applications' is an innovation action in Horizon 2020, the most significant research programme in the European Union. Aimed at reducing the production costs of fuel cell systems in transport applications while increasing their lifetime to levels that can compete with conventional technologies, the programme has awarded the project entitled FCH2RAIL, under Grant Agreement No. 101006633 [1].

The main objective of the FCH2RAIL project is to develop, build, test, demonstrate and homologate a scalable, modular and multi-purpose Fuel Cell Hybrid PowerPack (FCHPP) applicable for different rail applications as well as suitable for retrofitting existing electric and diesel trains, to reach TRL7.

The goal of the Task 2.2 included in the WP2 is to identify and define how the FCHPP for an innovative Bi-mode Fuel Cell Hybrid Multiple Unit fits into the vehicle architecture.

The scope of the Task 2.2 covers the definition of the main interfaces (mechanical, electric, fluidic, thermal, ventilation, control...) between the different subsystems of the FCHPP and the train, considering the key aspects for the integration. Where there is no specific railway standard covering the interface, codes of practices from other industries with experience handling hydrogen technology have been considered.

All these interfaces have been assessed analysing the safety integration of the FCHPP into the train. Several Hazard workshops have been carried out to identify potential risks and mitigation measures to be applied.

This document constitutes the Deliverable D2.2, titled "Train – FCHPP interface. Block schematic" for the FCHRAIL project, which is the deliverable for the Task 2.2.

The document shows the generic interfaces required for the installation of the FCHPP and define the key aspects and codes of practices to be considered to ensure a proper and safe integration of the FCHPP in a generic train.

Glossary of Terms

Abbreviations	Description
APS	Auxiliary Power Supply
BTMS	Battery Thermal Management System
FC	Fuel Cell
FCH	Fuel Cell Hybrid
FCHPP	Fuel Cell Hybrid Power Pack
EMC	Electromagnetic Compatibility
EMU	Electric Multiple Unit
ESS	Energy Storage System
ESU	Energy Storage Unit
GTU	Gas Treatment Unit
HRS	Hydrogen Refuelling Station
HV	Hight Voltage
MVB	Multifunction Vehicle Bus
PPS	Primary Power Source
P&ID	Piping & Instrumentation Diagram
TCMS	Train Control and Monitoring System
TPRD	Thermally activated Pressure Relief Device
DASEM	Driver Advisory System and Energy Management

Acronyms	Description
GA	Grant Agreement
FCH2Rail	Fuel Cell Hybrid Power Pack for Rail Applications

Contents

Executive Summary	iii
Glossary of Terms	iv
1. Background.....	3
2. Objective and Methodology.....	4
3. Fuel Cell Hybrid PowerPack.....	5
4. Fuel Cell Hybrid PowerPack – Train interfaces.....	9
4.1 FUEL CELL SYSTEM.....	10
4.1.1 Mechanical interfaces	10
4.1.2 Electrical interfaces	11
4.1.3 Fluidic interfaces	11
4.1.4 Control and Communication	13
4.2 FUEL CELL COOLING SYSTEM.....	13
4.2.1 Mechanical interfaces	14
4.2.2 Electrical interfaces	14
4.2.3 Fluidic interfaces	15
4.2.4 Thermal (heat dissipation)	16
4.2.5 Control and Communication	16
4.3 HYDROGEN STORAGE SYSTEM	16
4.3.1 Mechanical interface.....	17
4.3.2 Electrical interfaces	19
4.3.3 Fluidic interfaces	20
4.3.4 Ventilation interfaces	22
4.3.5 Control and communications	22
4.4 Battery System	23
4.4.1 Mechanical integration	24
4.4.2 Electrical interfaces	25
4.4.3 Thermal (heat dissipation)	25
4.4.4 Control and communications	26
4.5 HV DC/DC Converter	26

4.5.1	Mechanical interface	26
4.5.2	Electrical interfaces	27
4.5.3	Thermal (heat dissipation)	27
4.5.4	Control and communications	28
4.6	Driver Advisory System and Energy Management (DASEM).....	28
4.6.1	Mechanical integration	29
4.6.2	Electrical interfaces	29
4.6.3	Control and communications	30
5.	Conclusions.....	31
6.	References.....	32
A.1	List of Figures.....	34
A.2	List of Tables	34

1. Background

Starting from the requirements for the next generation of Bi-mode Fuel Cell Hybrid train identified in WP1 (through D1.2 [2]), the aim of the WP2 is to produce the technical definition of the train Demonstrator that will be used to test and demonstrate the operational performance of a Bi-mode FCH multiple unit with the capability of operating both, under catenary as well as on non-electrified routes.

The first task (Task 2.1 [3]) of WP2 started considering how the generic requirements that have been defined in WP1 could be applied to the specific Train Demonstrator, and how this application generates new requirements for the design of the FCHPP.

In parallel to this task, the technical concept, architecture and performance of the FCHPP has been defined in WP3 (through D3.1 [4]). The solution for the FCHPP is expected to be modular and scalable to be able to cope with most of the aforementioned targeted application fields.

As the FCHPP is a complex system in which several subsystems are integrated, vehicle characteristics such as high voltage power supply, traction architecture, gauge, floor height etc. have a major impact in the configuration of the most suitable FCHPP for each application. As a common point, the main generic interfaces required for the safety integration of the FCHPP into a generic train have to be defined.

In Task 2.2, the definition of all these interfaces (mechanic, electric, fluidic, thermal, control etc.) between the different subsystems of the FCHPP and the train has been covered, defining the principals about how the FCHPP for an innovative Bi-mode Fuel Cell Hybrid Multiple Unit shall be fitted into the vehicle architecture.

2. Objective and Methodology

The objective of D2.2, which is the deliverable of Task 2.2, is to define how the FCHPP for an innovative Bi-mode Fuel Cell Hybrid Multiple Unit fits into the vehicle architecture.

The scope of this deliverable covers the definition of all the interfaces (mechanic, electric, communication, fluid, thermal etc.) between the different subsystems of the FCHPP and the train.

In order to define those interfaces, the first step is to identify all of them and review the key aspects to be considered for the integration of the FCHPP into the vehicle. Afterwards an analysis of each interface previously identified is carried out. Accompanying this process, a safety assessment has been carried out when interfaces as well as subsystem integration is conducted.

At the end of task 2.2, deliverable D2.2. is produced, which shows the definition of the generic interfaces required for the integration of the FCHPP in a generic train.

3. Fuel Cell Hybrid PowerPack

As described in IEC 62864-1 [5] standard, a series hybrid system has two or more power sources, including one Energy Storage System (ESS), and the traction equipment which serves as the primary power sink (the term “power sink” is used to denote subsystems that receive power from the link block). The system may have a secondary power sink, such as brake resistor, in case the power sources are either entirely or partly unreceptive of the power generated by the traction equipment during the regenerative braking. In addition to these main circuit subsystems, the series hybrid system may have one or more Auxiliary Power Supplies (APS). When connected electrically to the main circuit subsystems, the auxiliary loads shall be considered because of their significant impact on the energy consumption.

From a high-level perspective, traction system architectures of railway vehicles with electric traction motors are always built up in the same structure. This basic structure is well-know, even in the more complex series hybrid vehicles.

Figure 1 shows the block diagram of the Bi-mode Fuel Cell Hybrid Multiple Unit.

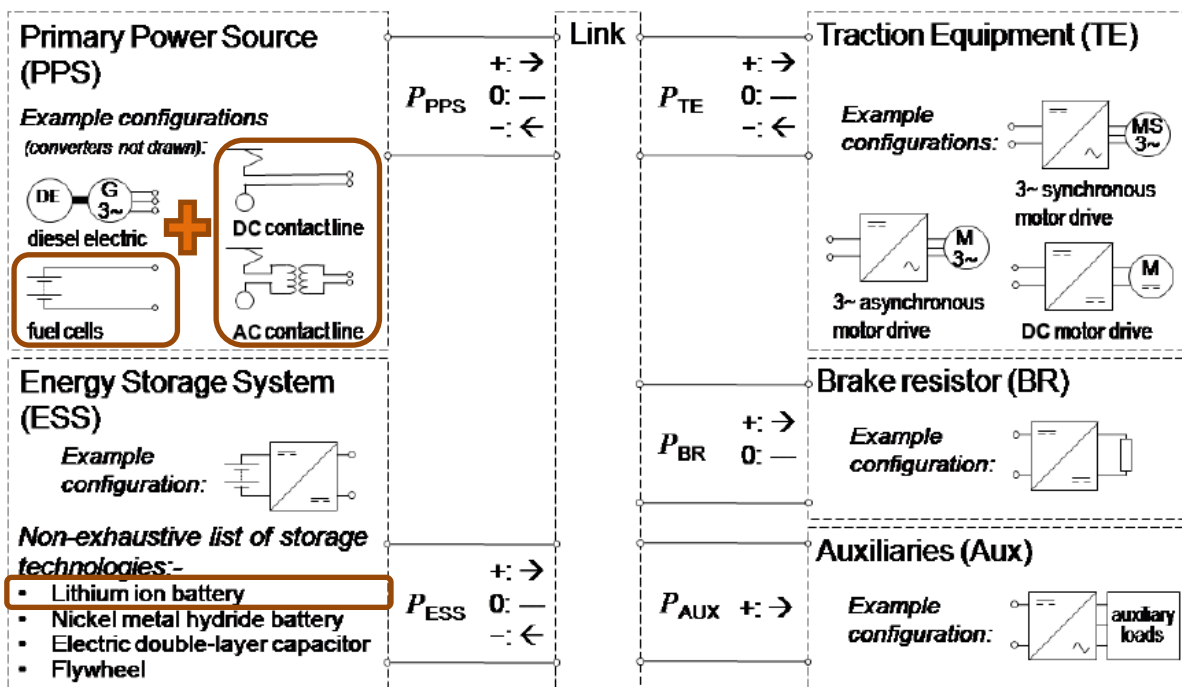

Figure 1 – Block diagram of a bi-mode hybrid system, encircled are the respective components for a bi-mode fuel cell hybrid system (source: IEC 62864-1, modified)

In this figure, the five main subsystems (Primary Power Source, Energy Storage System, Traction Equipment, Brake Resistor and Auxiliaries) are all connected to the common DC link.

In a Bi-mode Fuel Cell Hybrid Multiple Unit, two PPS (overhead catenary and fuel cells) and Battery Energy Storage System are installed (on the left-hand side of the figure). The Traction Equipment, Brake Resistors and Auxiliaries, represented on the right-hand side, are the consumers.

The voltage level of the common DC-link is dependent on the overall power requirements of the consumers; simplifying, it can be assumed that the voltage level increases with power demand to reduce current flows and resulting losses due to ohmic resistances as well as over dimensioned wire sizes, with the aim to increase system efficiency.

As per the current state-of-the-art, output voltages of Fuel Cell and Battery Systems are low compared to the DC-link voltages used in mainline railway applications.

The concept of FCH2RAIL aims on resolving this conflict by means of adapting the power electronics between FCHPP and DC-link; the power electronics are designed to connect a Hybrid Power Pack consisting of Fuel Cells and Batteries with the specific DC-link voltage used in the specific railway application.

The Fuel Cell Hybrid PowerPack is a hybrid system that integrates two power sources on-board, Fuel Cells (second PPS) and Battery System (ESS), to achieve the following main objectives:

- Replace diesel power sources with hydrogen fuel cells to achieve local zero emission operation
- Improve system efficiency compared to diesel units currently running
- Increases coverable range on non-electrified sections with the fuel cell compared to battery electric multiple units

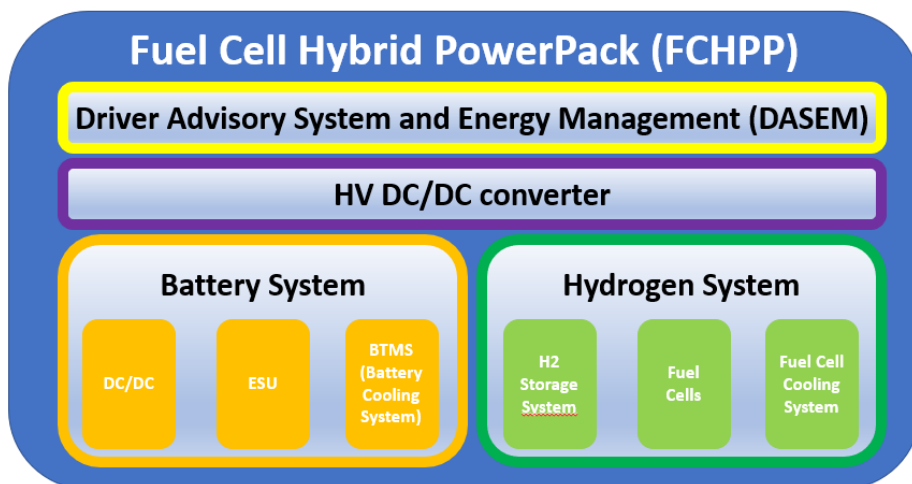

Figure 2 – Fuel Cell Hybrid PowerPack

The FCHPP is a new concept of an alternative energy supply system that complements or replaces the overhead contact lines to power the railway vehicles. This allows to optimize the use of the energy in the different operating modes:

- Overhead contact lines: the conventional electric train can also regenerate energy not absorbed by the overhead line into the batteries. In this mode of operation, the Hydrogen subsystem is switched off to reserve the use of hydrogen for non-electrified lines.
- Non-electrified lines: the electric train operates in hybrid mode. Hydrogen and Battery technologies are combined by implementing an integrated Driver Assistance System (DAS) with an optimal on-board Energy Management (EM) strategy operating jointly between the Hydrogen Fuel

Cell and Batteries. DASEM combined system optimizes the energy management of the vehicle in all operating modes.

Figure 3 and Figure 4 show the concept of integrating the FCHPP into a traction chain of a conventional DC or AC electric train respectively.

While the electric DC power vehicle permits to have a common traction bus, AC units have an independent traction DC-Link so one FCHPP could only feed one traction chain.

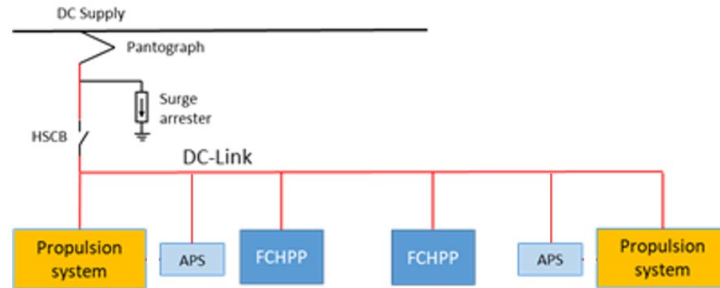

Figure 3 Generic DC train architecture

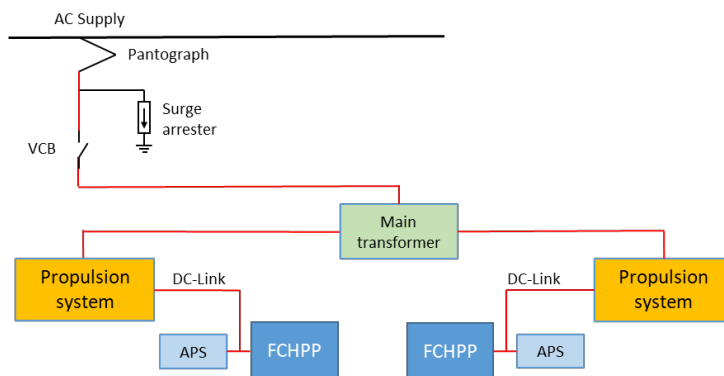

Figure 4 Generic AC train architecture

The FCHPP main subsystems are the following ones:

- Fuel Cell
- Fuel Cell cooling system
- Hydrogen storage system
- Battery system (DC/DC+ESU+BTMS)
- HV DC/DC converter
- Driver Advisory System and Energy Management (DASEM)

This results in the architecture defined in the following Figure:

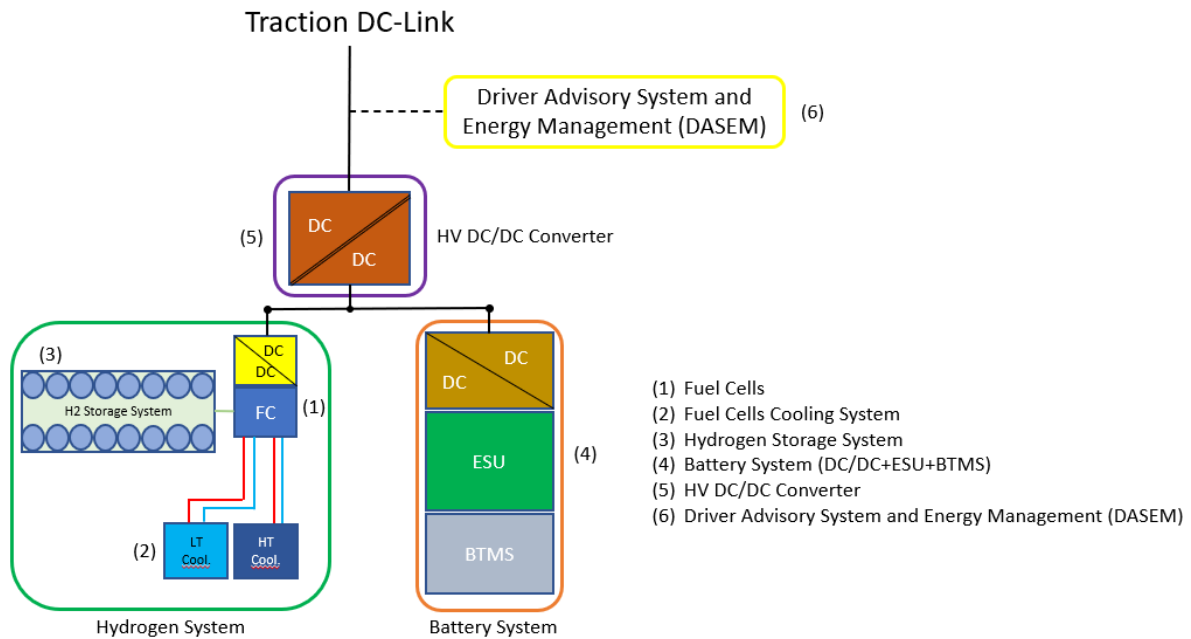

Figure 5 FCHPP architecture

Based on the power and energy requirements, basic building blocks for the Fuel Cell (and Fuel Cell Cooling System), Battery System and Hydrogen Storage System have been defined to develop a modular and scalable FCHPP, which is able to respond to the different power needs of each railway application. Depending on the vehicle traction architecture, performances and reliability requirements, a different number of FCHPPs can be integrated into the vehicle.

The FCHPP architecture depicted in Figure 5 has been defined considering the specific conditions of the train demonstrator in which this FCHPP is going to be integrated as part of the FCH2RAIL project. Alternative FCHPP configurations can be defined to fit different vehicle and traction architectures.

4. Fuel Cell Hybrid PowerPack – Train interfaces

This section defines key interfaces identified for the integration of the FCHPP into a generic train.

The FCHPP interfaces can be divided into the following main groups:

- Mechanical interfaces
- Electrical (main power and auxiliary supply) interfaces
- Fluidic (fuel supply, coolant, exhaust) interfaces
- Thermal (heat dissipation) interfaces
- Ventilation interfaces
- Control and Communication interfaces

Before detailing interfaces of each subsystem of the FCHPP, key generally applicable railway standards that shall be considered for the integration of the FCHPP into the train are listed below:

- **Mechanical interfaces:**

- EN 12663-1 [6]: Railway applications – Structural requirements of railway vehicle bodies – Part 1: Locomotives and passenger rolling stock (and alternative method for freight wagons)
- EN 15227 [7]: Railway applications – Crashworthiness requirements for rail vehicles
- EN 50125-1 [8]: Railway applications – Environmental conditions for equipment – Part 1: Rolling stock and on-board equipment
- EN 61373 [9]: Railway applications – Rolling stock equipment – Shock and vibration tests

- **Electrical interfaces:**

- EN50121-3-2 [10]: Railway applications – Electromagnetic compatibility – Part 3-2: Rolling stock - Apparatus
- EN 50153 [11]: Railway applications – Rolling Stock – Protective provisions relating to electrical hazards
- EN 50163 [12]: Railway applications – Supply voltages of traction systems
- EN 50306 [13]: Railway applications - Railway rolling stock cables having special fire performance - Thin wall
- EN 50264 [14]: Railway applications - Railway rolling stock power and control cables having special fire performance
- UIC 533 [15]: *Vehicles, protection by earthing of metal parts*

The following sections of this document describe the key interfaces of each subsystem of the FCHPP. All these interfaces have been assessed in parallel with the safety analysis (identification of hazards, judgement on risk, adequate mitigation and validation).

4.1 FUEL CELL SYSTEM

The Fuel Cell System is composed of at least of one fuel cell stack or one fuel cell power module, a fuel and an oxidant management system, a thermal management system, an exhaust management system, and a fuel cell control system.

The fuel cell power system can include several fuel cells connected in parallel to provide the required train performance.

Figure 6 shows the block diagram for the Fuel Cell System, identifying its boundaries and interfaces.

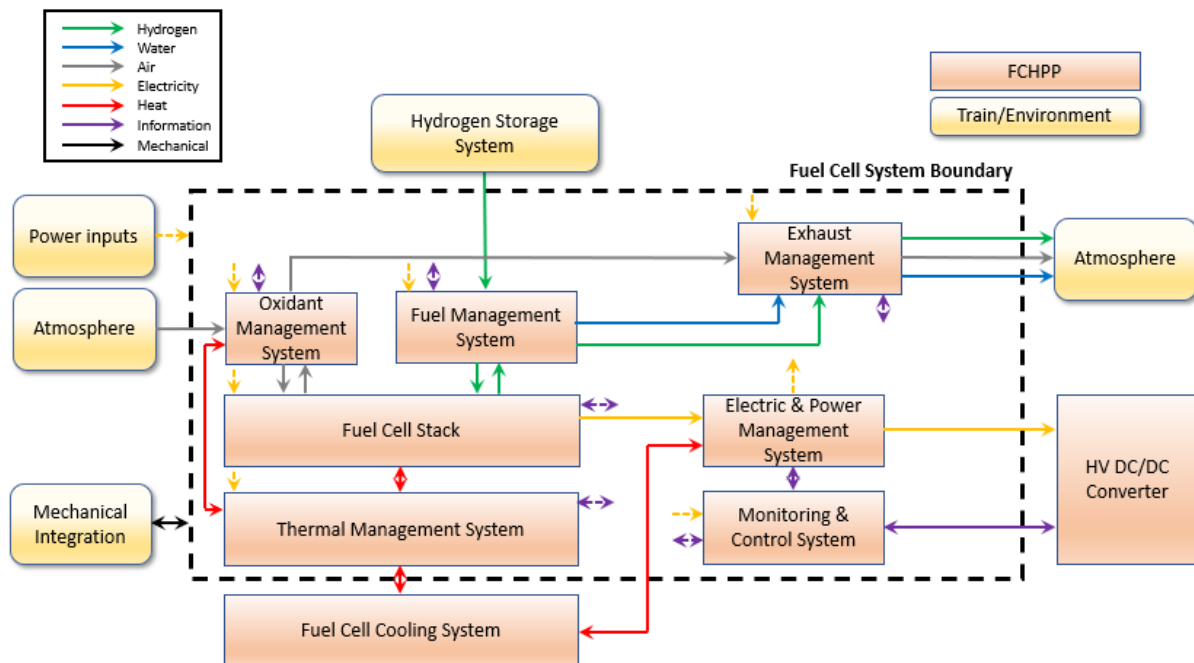

Figure 6 Fuel Cell System Block Diagram

4.1.1 Mechanical interfaces

Installing the Fuel Cell System on the vehicle roof has safety advantages (no hydrogen can accidentally escape into the passenger compartment) and benefits for the FC cooling system. However, in cases where gauging restrictions does not allow the Fuel Cell System to be installed on the roof, installation in the interior of the vehicle can be considered if safety aspects are properly addressed (e.g. risk of hydrogen leak).

4.1.2 Electrical interfaces

The electrical interface can be divided in the following types:

- Low voltage power supply and control
- High voltage power output
- Insulation
- Earthing

4.1.2.1 Power input

Low voltage power supply and control interface includes all the interfaces, which electrically feed the different components of the Fuel Cell.

Low voltage system required a 12 Vdc power supply. Power converters could be used to convert the voltage required by the Fuel Cell to the voltage commonly used in railway applications (24-110 Vdc).

4.1.2.2 Power output

Fuel Cell 700 Vdc power output is connected to the HV DC/DC converter.

A bolted connection is used for the power output.

4.1.2.3 Insulation resistance

A large insulation resistance between the low voltage system and the high voltage system of the FC shall be ensured so that current does not flow. Furthermore, it is necessary to monitor the insulation resistance to check the insulation status of the FC high voltage system.

4.1.2.4 Earthing

The case of each high voltage unit shall be connected to the vehicle body using the earth connections.

4.1.3 Fluidic interfaces

4.1.3.1 Fuel (hydrogen) supply

The Fuel Cell System interface for the fuel supply is defined according to the following parameters:

- Hydrogen fuel quality: Type I Grade D (ISO 14687 [16])
- Hydrogen nominal working pressure: 13 bar
- Temperature range (full performance): -30°C +50°C
- Minimum flow rate:

$$\text{H}_2 \text{ usage} = 1.05 \times 10^{-8} \times \frac{P_e}{V_c} \text{ kg s}^{-1}$$

Where:

P_e = Power

V_c = The voltage of each cell in the stack

The leak tightness of the connections between the hydrogen pipes and the Fuel Cell is ensured with a polymer gasket (O-ring).

4.1.3.2 Air intake

The air intake of the oxidant management system shall be positioned to ensure that only fresh air is supplied to the oxidant management system, and that the resistance to environmental factors such as rain, hail and snow shall also be taken into account in the integration of the oxidant supply inlet.

In the integration of the air intake, and airflow rate according with the following equation shall be ensured:

$$\text{Air usage} = 3.57 \times 10^{-7} \times \frac{P_e}{V_c} \text{ kg s}^{-1}$$

Where:

P_e = Power

V_c = The voltage of each cell in the stack

4.1.3.3 Coolant

This is an internal interface within the subsystems of the FCHPP.

Fuel Cells produce heat that must be dissipated by a cooling system. The Fuel Cell module contains the components for the cooling system although the heat dissipation is carried out using an external radiator.

The Fuel Cells has two independent cooling systems:

- High Temperature cooling system. This cooling circuit is used mainly to dissipate the heat generated by the FC stack.
- Low temperature cooling system. This cooling circuit dissipates the heat generated by the power systems inside the Fuel Cell module.

Coolant interfaces between the Fuel Cell and the Cooling System are listed below:

- HT cooling outlet (to radiator)
- HT cooling inlet (from radiator)
- HT degassing lines
- LT cooling inlet (from radiator)
- LT cooling outlet (to radiator)

4.1.3.4 Exhaust

The exhaust interface shall be located in position to avoid any issues with other subsystems (such as the air intakes for the oxygen management system and the cooling system) and its surroundings. In addition, it shall be positioned in such a manner to avoid mixed gas flow recirculation through the operators or passengers' compartment in the interior of the vehicle.

Additionally, external influences such as rain, hail and snow shall be considered for the integration of the oxidant supply inlet layout.

The exhaust pipe drains and exhausts "water", "nitrogen" as well as "hydrogen". The exhaust pipe shall be designed so that air and hydrogen are sufficiently mixed. Following EC134/2019 [17] (for road vehicles) the hydrogen concentration level shall:

- Not exceed 4% average by volume during any moving 3s time interval during normal operation including start-up and shut-down.
- Not exceed 8% at any time

4.1.4 Control and Communication

Control interface includes all of the interface to supply the different safety, control and monitoring devices electrically.

The Fuel Cell control is executed by a combination of communication and hardwired commands. Most of the commands will use the communication link between the controllers inside the FCHPP, but there are some wired input/output signals connected to the Train Control and Management System and DASEM.

Main control functions of the FCHPP are:

- Start and stop
- Insulation monitoring
- Conductivity monitoring of the coolant
- Purge stop
- Power demand
- H2 leak detection
- Hydrogen supply shut off
- Fuel Cell emergency switch off

Fuel Cell are connected to the HV DC/DC converter via CAN bus.

4.2 FUEL CELL COOLING SYSTEM

The Cooling System is a system for cooling the Fuel Cells. Cooling is carried out via a liquid, circulating cooling media. A water/glycol mixture is used as the cooling media.

4.2.2.2 Earthing

The Fuel Cell Cooling System shall be grounded to the vehicle body using the earth connections.

4.2.3 Fluidic interfaces

4.2.3.1 Coolant

This is an internal interface within the subsystems of the FCHPP. During operation, Fuel Cells produce heat that has to be dissipated by a cooling system. The Fuel Cell module contains the components for the cooling system although the heat dissipation is carried out using an external radiator.

The HT cooling unit has a feed flow and a return flow to which the Fuel Cell is connected. In addition, there is one connection each for filling the pump and a connection for venting the Fuel Cell. Furthermore, there is a drain connection and an overflow connection. The overflow connection is used to reach the target fill level during initial filling. Both design of both connections is carried out with a ball valve, which is closed during normal operation.

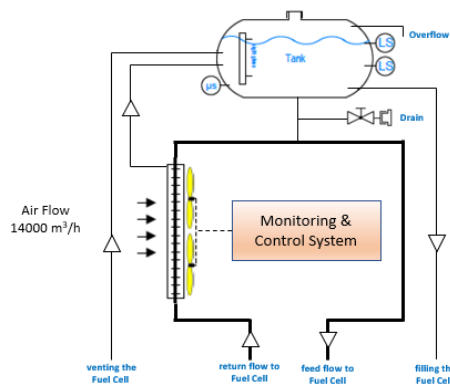

Figure 8 - HT Cooling System hydraulic interface

The LT cooling unit has a feed flow and a return flow to which the fuel cell is connected. Furthermore, there are two drain connections (heat exchanger and tank) and an overflow connection. The overflow connection is used to reach the target fill level during initial filling. All connections are designed with a ball valve, which is closed during normal operation.

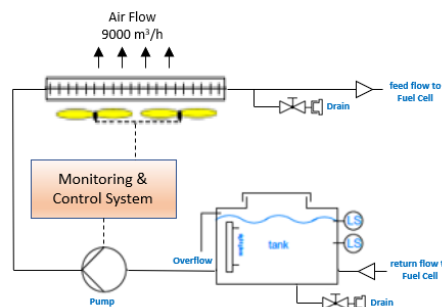

Figure 9 - LT Cooling System hydraulic interface

4.2.4 Thermal (heat dissipation)

To dissipate the heat produced by the Fuel Cell, the cooling system shall be integrated into the vehicle ensuring high air flows through the radiators.

The Fuel Cell heat dissipation can be estimated according to the following formulae:

$$P_{\text{therm, HHV}} = (1.481 \text{ V} - A_{\text{veCell}}) \cdot N \cdot I = P_{\text{el}} \left(\frac{1.481 \text{ V}}{A_{\text{veCell}}} - 1 \right)$$

Where: P_{el} = Power

A_{veCell} = The voltage of each cell in the stack

4.2.5 Control and Communication

Control interface includes all of the interface to supply the different safety, control and monitoring devices electrically.

The Fuel Cell Colling System control is carried out by a combination of communication and hardwired commands.

Main control functions are:

- FC Cooling System start up
- Coolant leak detection

The Fuel Cell Cooling System is connected to the Train Control and Monitoring System via CAN bus.

4.3 HYDROGEN STORAGE SYSTEM

Each FCHPP is equipped with a hydrogen storage system to store gaseous hydrogen up to a nominal working pressure of 350 bar.

The Hydrogen Storage System is composed of:

- One (or more) hydrogen tank assembly (assemblies) having the main function of gas storage in safe conditions
- One (or more) gas treatment unit(s) distributing hydrogen from the tanks to the fuel cell power systems in the expected conditions of pressure and flow
- One (or more) refilling station interfaces
- Connecting piping linking the above components

The tank assembly is composed of several hydrogen vessels mounted on a structural frame, connected by piping and equipped with control, safety and monitoring devices (e.g. OTV valve, TPRD, sensors...).

There is a wide number of vessel configurations (length, diameter...) in the market providing different capacities. The type and arrangement of the vessels within the frame can be adapted to optimize the use of the available space and weight distribution in the vehicle. To reach the requested capacity, several tank assemblies connected can be installed in the vehicle.

Figure 10 shows the block diagram for the Hydrogen Storage System, identifying its boundaries and interfaces.

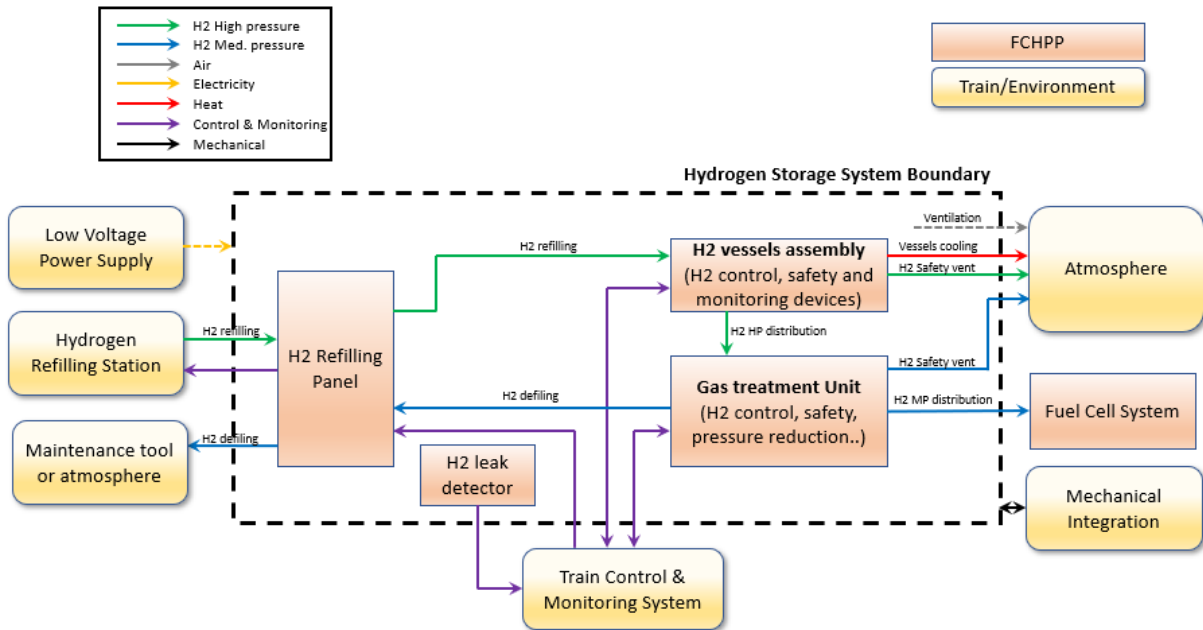

Figure 10 – Hydrogen Storage System Block Diagram

4.3.1 Mechanical interface

As there is currently no specific standard for Railway applications, the following regulation for hydrogen-powered motor vehicles should be considered:

- EC 79/2009 [18]: Type-approval of hydrogen-powered motor vehicles
- EU 406/2010 [19]: Implementing Regulation EC79

Requirements for the installation of hydrogen components and systems detailed in Annex VI of the EC 79/2009 [18] should be implemented in the integration of the FCHPP into the vehicle.

In particular, due to high flammability properties of hydrogen, all sub-assemblies of the Hydrogen Storage System storing or conveying hydrogen shall be separated from areas occupied by passengers or staff personnel or areas in the proximity to devices that can generate sparks.

The suitable installation of the Hydrogen Storage System in railway applications is on the roof or inside a technical compartment in the interior of the vehicle, more rarely in the underframe. In all cases,

specific precautions shall be taken to avoid any risk of accumulation of potentially leaked hydrogen, considering that hydrogen is lighter than air and thus can accumulate on cabinet covers, compartment ceilings, etc.

Classification of the hazardous areas shall be conducted following the methodology on the IEC standard and European norm EN 60079-10 [20] “Explosive atmospheres – Part 10-1: Classification of areas – Explosive gas atmospheres”. This is a widely acknowledged international standard/norm and is accepted/approved by Fire and Safety Authorities in Europe and internationally.

Following this standard, the classification of zones shall be estimated by assessing the likelihood of a potentially explosive atmosphere to occur (likely frequency and duration), and its extensions by assessing the area/volume of the potentially explosive atmosphere. Depending on the integration of the Hydrogen Storage System in the train (and the likelihood of a potentially explosive atmosphere to occur), requirements for ventilation, hydrogen leak detection and characteristic of the electrical components will be established.

If the Hydrogen Storage System is installed inside a technical compartment in the interior of the vehicle, the compartment shall be properly vented to the atmosphere. The confined space should have hydrogen detectors to detect the presence of hydrogen and to avoid the build-up of a flammable mixture. The hydrogen detectors are typically placed above a potential leak point and where hydrogen may accumulate, which is usually at the highest point of the confined space.

Mechanical integration of the Hydrogen Storage System shall also consider the following thermal constraints:

- Condensation of humidity or formation of ice on hydrogen circuit and devices due to potential very low temperature, in case of cooled hydrogen refilling.
- High temperature of hydrogen tanks and associated circuit during the refilling process.

Piping and fittings connecting the subsystems of the FCHPP need to be suitable for hydrogen over the service life of the system. The pipes and fitting dimensions shall be carried out considering the hydrogen working pressure and mass flow. A specific focus shall be given about the selection of materials in contact with hydrogen to avoid the risk of hydrogen embrittlement as outlined in ISO/TR 15916 [21].

For the integration of the FCHPP, and considering the aspects detailed above, 316 stainless steel seamless tube is the most suitable piping material. In general, it is recommended using rigid pipes over flexible pipes due to their better structural integrity and longer service life.

Rigid fuel lines shall be secured such that they are not subjected to abrasion, critical vibration and/or other stresses. Lines shall be routed to minimize exposure to accidental damage. At the fixing points, the fuel lines shall be fitted in such a way that they cannot make a metal to metal contact to prevent galvanic and crevice corrosion.

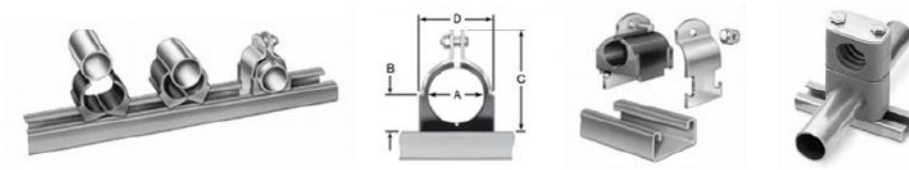

Figure 11 – Some examples of fixing clamp for fuel lines

For piping connections, welded joints are preferred, but some joints may require periodic opening for maintenance activities, removable connections are required. The number of connections shall be limited to a minimum. Any joint shall be made in locations where access is possible for inspection and leak testing.

Double ferrule fittings should be used to connect the high-pressure fuel lines, because of their ability to provide tight seals.

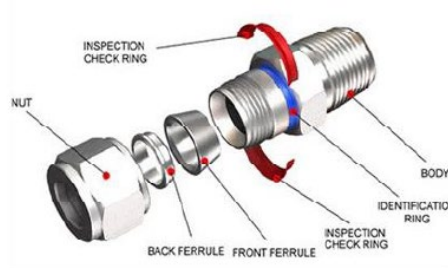

Figure 12 – Double ferrule fitting

Finally, alarms and warning devices should be installed to provide an alarm in the event of a potentially hazardous situation.

4.3.2 Electrical interfaces

4.3.2.1 Power input

Low voltage power supply and control interface includes all the interfaces to the different safety, control, and monitoring devices supplied electrically.

Low voltage system requires a 24 Vdc power supply. Power converters could be used to convert the required voltage to the train voltage.

4.3.2.2 Earthing

Electrically conductive housings of components and all the piping in possible flammable areas should be bonded to the vehicle body using the earth connections avoiding the occurrence of any electrostatic discharge to prevent inadvertent ignition of hydrogen.

This is especially important for the refilling of the tanks, as during this process it is important to ensure the hydrogen refilling station is connected to the same earthing point to avoid the occurrence of any electrostatic discharge.

4.3.3 Fluidic interfaces

Figure 13 shows a simplified P&ID for the hydrogen installation of the FCHPP into the train.

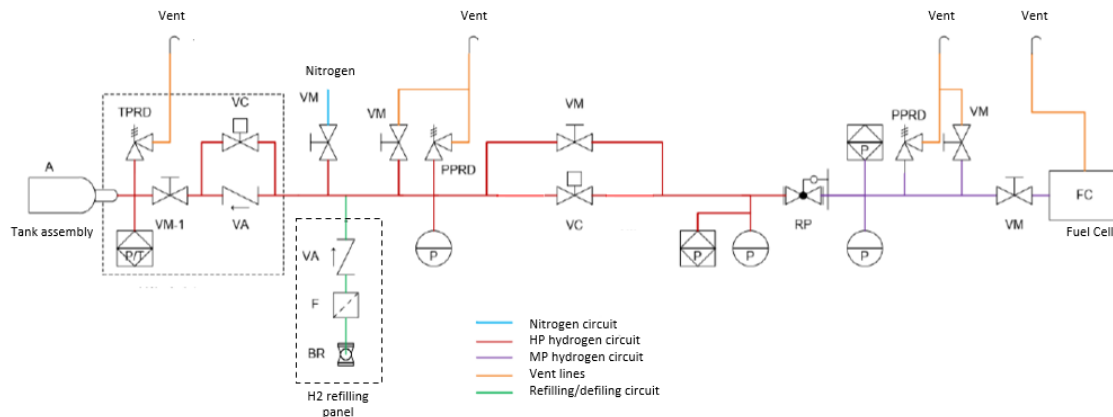

Figure 13 – Simplified P&ID

4.3.3.1 Fuel (hydrogen) refilling

Hydrogen refilling station interface is composed of the on-board hydrogen connector (receptacle), the station-to-train communication interface (further details in section 4.3.5) and hydrogen devices such as filters, check valves, etc.

Nozzles and receptacles are the connection devices between the refuelling station and the vehicle. The FCH JU Project PRHYDE (Deliverable 2.4) has collected the standards that regulate the requirements for nozzles and receptacles for compressed gaseous hydrogen. These standards are ISO 17268 [22] and SAE J2600 [23], both of which specify compatibility between nozzles and receptacles considering the nominal operating pressure and also, in the 35 MPa vehicle case, the mass flow rate.

Currently, no specific nozzles and receptacles have been developed for the refuelling of rail vehicles, but considering its similarities, the nozzle-receptacle used for heavy-duty road vehicles (lorries and trucks) can be adopted, which provides fast filling and high flow mass.

WEH, the leader manufacturer of these receptacles, offers two different models for fast filling and high flow:

- Receptacle TN1 H2 (complies with ISO 17268 [22]) and the corresponding nozzle TK16 H2 (available with and without communications integrated)
- Receptacle TN5 H2 and the corresponding nozzle TK25 H2 (not available with integrated communications)



Figure 14 – WEH nozzle-receptacle for heavy-duty vehicles

The receptacles shall be mounted at a height between 700 mm and 1500 mm above rail level, at least one on each side to allow easy access for the operator.

The extremity of the receptacle shall be equipped with a soft protective cap on the active part, to prevent pollution of dust or other contaminants.

The access to the hydrogen connector shall be prevented to non-authorized personnel by a locked cover or hood (paying attention in its design to prevent any possible accumulation of hydrogen that may leak during filling operations).

4.3.3.2 Fuel (hydrogen) supply

The hydrogen store on-board is supplied from the Gas Treatment Unit (pressure regulator, filter...) to the Fuel Cell. The GTU is connected to the FC through medium pressure hydrogen circuits, i.e. rigid stainless steel pipes and fittings.

4.3.3.3 Fuel (hydrogen) emptying

A hydrogen gaseous interface shall be foreseen to allow emptying the high pressure and medium pressure circuits of the Hydrogen Storage System for maintenance purposes. It shall allow typical maintenance operations to be completed on sub assembly (e.g. GTU) without being obliged to completely vent the hydrogen storage capacity.

4.3.3.4 Release (venting) of hydrogen

Each tank (or assembly of tanks) is able to safely release hydrogen into the atmosphere through TPRD valves in case of fire. Taking the high flammability properties of the hydrogen into account, the venting pipe design (orifice diameter, flow direction, etc.) shall consider that hydrogen could burn as soon as it is mixed with external air. Therefore, hydrogen release interfaces of the Hydrogen Storage System shall be designed to avoid any issue with other subsystems and its surroundings. In particular, the orientation of the venting pipes shall prevent any accumulation of hydrogen in areas where staff or passengers could be present.

Venting pipes shall also consider potential presence of rain, hail, frost and snow in designing and positioning the exhaust outlet in the vehicle.

The Hydrogen Storage System is also equipped with a safety release valve (PPRDs) in the medium pressure hydrogen circuit that is activated in case of overpressure (e.g. failure of the regulator). The venting pipes shall be treated with the same precautions as for hydrogen release in case of opening of the TPRD.

4.3.4 Ventilation interfaces

If the Hydrogen Storage System is installed inside a confined space in the interior of the vehicle, the compartment shall be properly vented to the atmosphere. The ventilation opening shall be at the highest point of the housing and shall not discharge at a heat source. Additionally, it shall discharge such that hydrogen cannot enter the inside of the vehicle and/or accumulate in an enclosed or partially enclosed space.

A ventilation system should remove hydrogen from the confined space or at least keep its concentration below the appropriate lower flammability limit. Hydrogen leaks in a non-ventilated confined space can readily form ignitable gas mixtures. Consequently, confined spaces containing equipment for handling or storing of hydrogen should always have an active or passive ventilation system.

4.3.5 Control and communications

Control interface includes all the interface to electrically feed the different safety, control, and monitoring devices.

The Hydrogen Storage System provides information to the Train Control and Management System related to pressure and temperature of the tanks, pressure after the regulator (medium pressure), the presence of hydrogen and the activation of safety devices (TPRD, pressure relief valve, excess flow valve...).

The TCMS shall control the opening/closing of the on-tank solenoid valves with high integrity level to safely interrupt hydrogen distribution in the following cases:

- hybrid mode not selected
- major failure in the Fuel Cell
- high or medium pressure above limits
- excessive temperature in the tanks
- excess flow valve activation
- H₂ leak detection
- request by driver or rescue team (activation of an emergency mushroom pushbutton)

It shall be ensured that the propulsion system cannot be operated and the vehicle cannot move while the fuelling receptacle is connected to the filling station.

In the event of any abnormal condition, malfunction or failure, an audible and visual alarm shall be triggered in the cab to alert the driver.

In case that an active ventilation system is required to avoid the build-up of a flammable mixture of hydrogen, ventilation shall be active (low speed) in all conditions, and if hydrogen leak is detected, maximum speed of the ventilation system shall be triggered.

If the Hydrogen Storage System is installed inside a technical compartment in the interior of the vehicle, the compartment shall be properly vented to the atmosphere. The confined space should have hydrogen detectors to detect the presence of hydrogen and to avoid the build-up of a flammable mixture. The hydrogen detectors are typically placed above a potential leak point and where hydrogen may accumulate, which is usually at the highest point of the confined space.

The hydrogen dispenser can conduct the filling process either with or without communication with the vehicle. In case communications are available between the Hydrogen Refuelling Station (HRS) and the vehicle, information such as tank capacity and real time values of pressure & temperature of tanks during refilling process shall be transmitted through a predefined protocol.

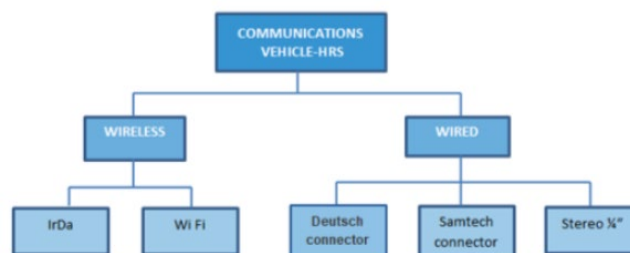

Figure 15 – Communication options between vehicle and HRS. Source: CNH2

The most typical hardware for wireless communication is the infrared data association (IrDa) and is often used with the protocol defined in SAE J2799 [24]. WiFi is another possible way of wireless communication between the nozzle and receptacle, but this method is not currently considered in any standard.

With regard to heavy-duty vehicles, the following wired connections have been tested:

- Deutsch connector: device with many pins standardised at California Fuel Cell Partnership (CaFCP)
- Samtech connector: device with small pins
- Stereo ¼" cable

4.4 Battery System

The Battery System is the electrical on-board energy storage system that allows energy to be stored on-board a vehicle and deploy it for traction purposes allowing the vehicle to run along sections

without catenary. Additionally, the excessive recuperated energy during decelerating phases which cannot be feedback into the catenary can be stored in the battery system.

The Battery System consists of different modules:

- Power Converter Unit (DC/DC) – Dual Buck-Boost DC/DC potential converter allowing a two-way flow of energy between the Battery System and the vehicle. The change of voltage allows energy to be stored at a lower voltage, leading to higher adaptability, redundancy, and safety.
- Energy Storage Unit (ESU) – Energy is stored in this module. The more suitable technology for FCHPP application is the LTO lithium-ion battery cell, which offers high cyclability and a high-power density. The type and quantity of energy storage modules can be configured to meet power and energy requirements.
- Battery Thermal Management System (BTMS) – This unit helps cooling down the system to the required target temperature regardless of weather conditions.

Figure 16 shows the block diagram for the Battery System, identifying its boundaries and interfaces.

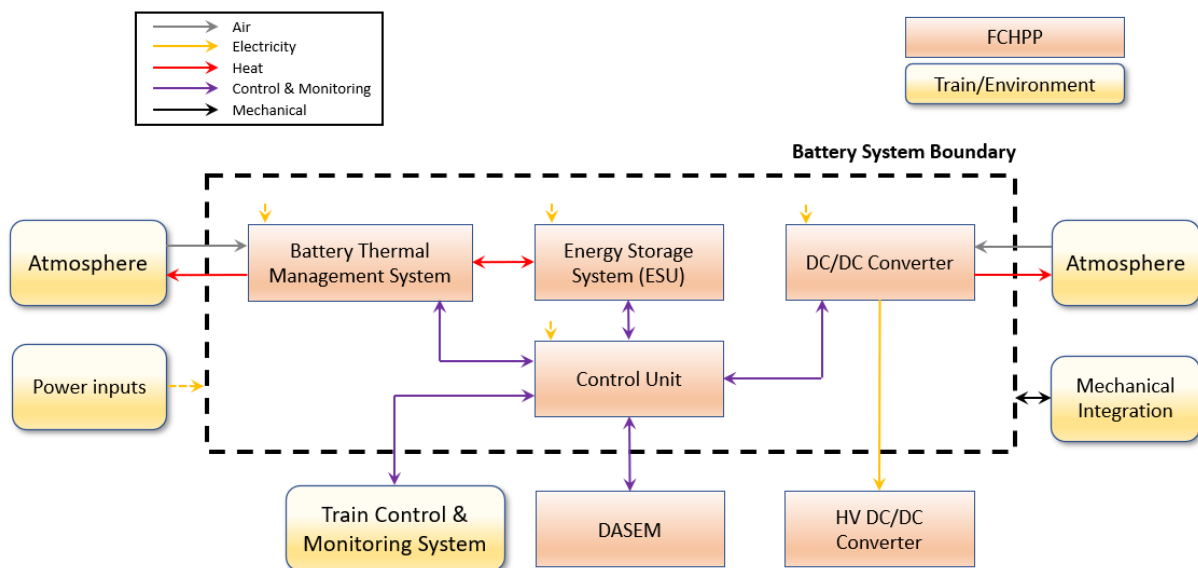

Figure 16 – Battery System Block Diagram

4.4.1 Mechanical integration

Battery System can be installed on the roof, inside a technical compartment in the interior of the vehicle or underframe.

If it is installed in the interior, the proper ventilation of the system to the atmosphere shall be ensured. In addition, it shall be confined and separated from passenger and staff areas by a fire barrier as required in EN 45545-3 [25].

4.4.2 Electrical interfaces

The electrical interface can be divided in the following types:

- Low voltage power supply and control
- High voltage power output
- Earthing

4.4.2.1 Power input

Low voltage power supply and control interface includes all the interface to supply the different components of the Battery System electrically. It can be divided in:

- 400 Vac power supply (required to power fan)
- 72 Vdc power supply (required to power monitoring and control components)

4.4.2.2 Power output

Battery System 700 Vdc power output is connected to the HV DC/DC converter. Depending on the train performance, several ESU can be connected in series.

A base connector mounted in the DC/DC is used for the high voltage power output.

4.4.2.3 Earthing

Each Battery System (DC/DC, ESU and BTMS) has two earthing points to connect the frame to the vehicle body, and it is compulsory to connect both.

4.4.3 Thermal (heat dissipation)

In contrast to other energy storage technologies, lithium-ion batteries are very sensitive to operating temperature, especially to cold and hot conditions. Thus, an active cooling system is needed to ensure a long service life of the equipment. The BTMS ensure the ESU battery cells will be in the optimum working temperature range by pumping a flow of liquid coolant between both systems.

To dissipate the heat produced by the ESU, the BTMS shall interchange with the ambient high air flow. Besides, the DC/DC shall also dissipate heat.

It would depend on the specific configuration of the Battery System, but as a reference, for a Battery System composed of 4 ESU, the following air flow shall be guaranteed:

- BTMS: 4500 m³/h
- DC/DC: 1200 m³/h

4.4.4 Control and communications

The Battery System control is performed by a combination of communication and hardwired commands. Most of the commands will use the communication link between the controllers inside the FCHPP but there are some wired input/output signals connected to the Train Control and Management System and DASEM.

Hardware signals are used to control safety functions with high integrity level as the functions detailed below:

- Fire detection (DO)
- Emergency brake (DI)

The Battery System is connected to the Train Control and Monitoring System and the DASEM via MVB.

4.5 HV DC/DC Converter

The High Voltage DC/DC Converter converts the 700 Vdc bus where the Fuel Cell and the Battery System are connected to the traction bus. The HV DC/DC provides galvanic isolation between the two circuits.

Figure 17 shows the block diagram for the HV DC/DC Converter, identifying its boundaries and interfaces.

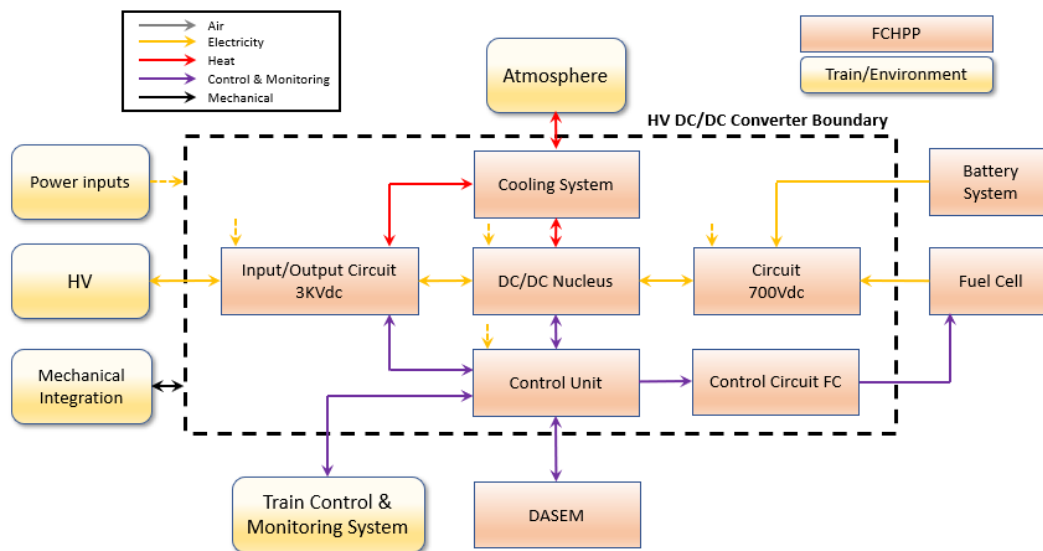

Figure 17 – HV DC/DC Converter Block Diagram

4.5.1 Mechanical interface

HV DC/DC Converter can be installed on the roof, inside a technical compartment in the interior of the vehicle or underframe.

If it is installed in the interior, a proper ventilation of the system to the atmosphere shall be ensured. The converter shall also be confined and separated from passenger and staff areas by a fire barrier as requested in EN 45545-3 [25]

4.5.2 Electrical interfaces

The electrical interface can be divided in the following types:

- Low voltage power supply and control
- High voltage power input&output
- Earthing

4.5.2.1 Low voltage power input

Low voltage power supply and control interface includes all the interfaces to supply the different components of the HV DC/DC converter electrically. It can be divided into:

- 400 Vac power supply (required to power fan)
- 72 Vdc power supply (required to power monitoring and control components)

4.5.2.2 High voltage power input&output

The HV DC/DC converter receives the 700 Vdc voltage from the Fuel Cell and the Battery System and provides the high voltage output to supply the traction equipment and the auxiliary power supply.

The high voltage power output shall be adapted to the train traction bus, according to the use cases identified, a solution for a 3000 and 1800 Vdc is required.

A base connector mounted in the DC/DC is used for the high voltage power input and output.

4.5.2.3 Earthing

Each HV DC/DC converter has two earthing points to connect the frame to the vehicle body, and it is compulsory to connect both.

4.5.3 Thermal (heat dissipation)

The heat produced to convert the 700 Vdc voltage to the traction bus voltage shall be dissipated. The cooling system shall circulate the high ambient air flow.

It would depend on the specific configuration of the FCHPP, but as a reference, the following air flow shall be guaranteed for the train demonstrator application.

- DC/DC: 5600 m³/h

4.5.4 Control and communications

The HV DC/DC converter control is performed by a combination of communication and hardwired commands. Most of the commands use the communication link between the controllers inside the FCHPP but there are some wired input/output signals connected to the Train Control and Management System and DASEM.

Hardware signals are used to control safety functions with high integrity level as the functions detailed below:

- Main Circuit Breaker closing permission signal (DO)

The HV DC/DC converter is connected to the Train Control and Monitoring System and the DASEM via MVB and to the Fuel Cells via CAN bus.

4.6 Driver Advisory System and Energy Management (DASEM)

The Driver Advisory System and Energy Management System (DASEM) is part of the FCHPP, and it controls and optimises the hybridization strategies using the different power sources in any mode of operation.

The DASEM consists of different modules:

- DASEM (Control Unit)
- DASEM HMI (Human-Machine Interface)
- Antenna GPS

Figure 18 shows the block diagram for the DASEM, identifying its boundaries and interfaces.

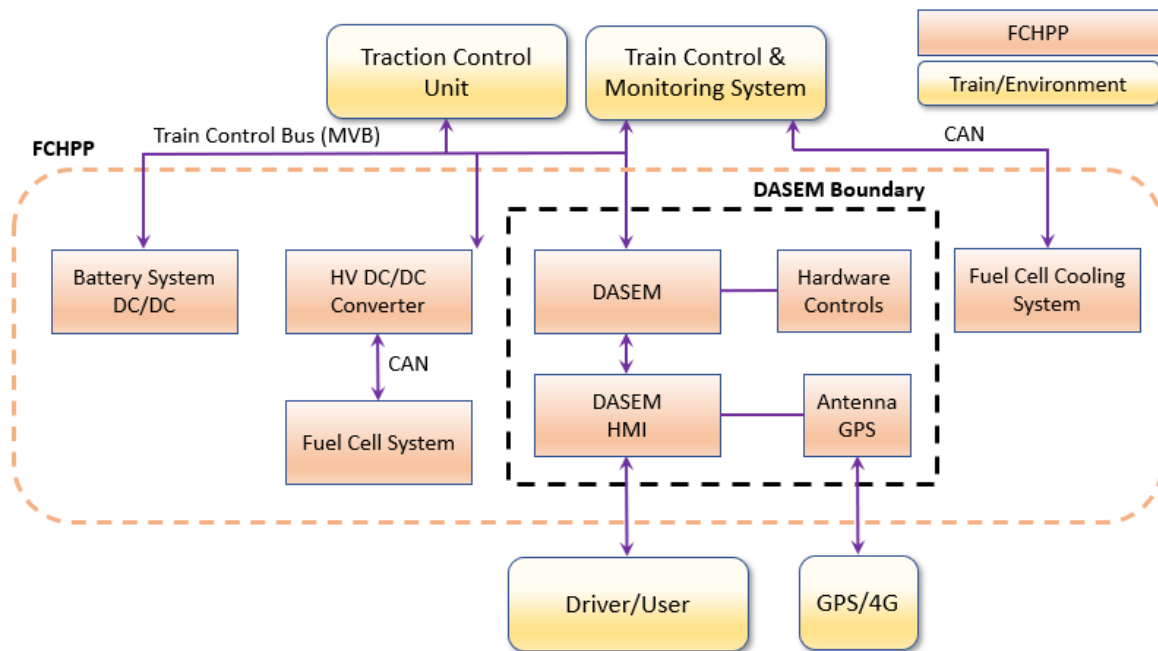

Figure 18 – DASEM Block Diagram

4.6.1 Mechanical integration

The DASEM HMI and hardware controls (switch, mushroom pushbutton, ...) are the main interfaces of the FCHPP with the driver and shall be installed in a central position of the driver desk in the cab.

The DASEM Control Unit should be installed inside a cabinet in the cab area.

Finally, the antenna GPS shall be installed on the roof, at a maximum distance of 5 m regarding the DASEM Control Unit.

4.6.2 Electrical interfaces

The electrical interface can be divided in the following types:

- Low voltage power supply and control
- Earthing

4.6.2.1 Low voltage power input

Low voltage power supply and control interface includes all the interface to electrically feed battery power supply and the control and monitoring signals.

The power supply can be adapted to standard railway low voltages, i.e. 24 Vdc, 72 Vdc or 110 Vdc voltages.

4.6.2.2 Earthing

Each component of the DASEM shall be connected to vehicle body by the earthing connections.

4.6.3 Control and communications

All the different controllers of the FCHPP shall be connected directly to the train control bus or by means of the Train Control and Monitoring System. The control bus shall be carried out according to IEC 61375-2-3 [26] (TCN) or IEC 61375-3-4 [27] (ECN).

The DASEM control is performed by a combination of communication and hardwired commands. Most of the commands will use the communication link between the controllers inside the FCHPP and the TCMS, but there are also some wired input/output signals for control.

Main control functions of the DASEM are:

- Selection of the operating mode (electric, hybrid, refuelling...)
- Main Circuit Breaker closing permission signal (DO)
- Establish the power to be provided by Fuel Cells and Battery System

5. Conclusions

The goal of Task 2.2 included in the WP2 is to identify and define how the FCHPP for an innovative Bi-mode Fuel Cell Hybrid Multiple Unit fits into the vehicle architecture.

The scope of the Task 2.2 covers the definition of the main interfaces (mechanic, electric, fluidic, thermal, ventilation, control...) between the different subsystems of the FCHPP and the train, considering the key aspects for the integration. Where there is no specific railway standard covering the interface, codes of practices from other industries with experience in handling hydrogen technology have been considered, like the EC79/2009 [18] and EC134/2019 [17] regulations applicable for hydrogen-powered motor vehicles.

All these interfaces have been assessed analysing the safety integration of the FCHPP into the train. Several Hazard workshops have been carried out to identify potential risks and mitigation measures which have to be applied.

This deliverable D2.2 shows the generic interfaces required for the installation of the FCHPP, and defines the key aspects and codes of practices to be considered to ensure a proper and safely integration of the FCHPP in a generic train. Due to the flexible deployment scenarios and the therefore resulting restrictions depending on the railway vehicle where the FCHPP will be integrated, have to leave a final and complete layout for the FCHPP subsystem open for the manufacturer.

6. References

- [1] European Commission, "Grant Agreement Number- 101006633 - FCH2Rail," 2020.
- [2] D1.2 Bi-mode Hybrid multiple unit Demonstrator requirements.
- [3] D2.1 Requirements Specification for a Bi-mode FCH Multiple Unit.
- [4] D3.1 FCHPP architecture, interfaces and functions.
- [5] *IEC 62864-1 Railway applications - Rolling stock - Power supply with onboard energy storage system - Part 1: Series hybrid system.*
- [6] *EN 12663-1: Railway applications - Structural requirements of railway vehicle bodies - Part 1: Locomotives and passenger rolling stock.*
- [7] *EN 15227: Railway applications - Crashworthiness requirements for rail vehicles.*
- [8] *EN 50125-1: Railway applications - Environmental conditions for equipment - Part 1: Rolling stock and on-board equipment.*
- [9] *EN 61373: Railway applications - Rolling stock equipment - Shock and vibration tests.*
- [10] *EN 50121-3-2: Railway applications. Electromagnetic compatibility Rolling stock. Apparatus.*
- [11] *EN 50153: Railway applications. Rolling stock. Protective provisions relating to electrical hazards.*
- [12] *EN 50163: Railway applications - Supply voltages of traction systems.*
- [13] *EN 50306: Railway applications - Railway rolling stock cables having special fire performance - Thin wall.*
- [14] *EN 50264: Railway applications - Railway rolling stock power and control cables having special fire performance.*
- [15] *UIC 533: Vehicles, protection by earthing of metal parts.*
- [16] *ISO 14687: Hydrogen fuel quality — Product specification.*
- [17] *EC134 - Motor vehicles and their components with regard to the safety-related performance of hydrogen-fuelled vehicles.*

- [18] *EC79 - Hydrogen powered motor vehicles.*
- [19] *EU 406-2010 - Implementing Regulation EC79.*
- [20] *EN 60079-10: Explosive atmospheres - Part 10-1: Classification of areas - Explosive gas atmospheres.*
- [21] *ISO/TR 15916: Basic considerations for the safety of hydrogen systems.*
- [22] *ISO 17268: Gaseous hydrogen land vehicle refuelling connection devices.*
- [23] *SAE J2600: Compressed Hydrogen Surface Vehicle Fueling Connection Devices.*
- [24] *SAE J2799: Hydrogen Surface Vehicle To Station Communications Hardware And Software.*
- [25] *EN 45545-3: Railway applications - Fire protection on railway vehicles - Part 3: Fire resistance requirements for fire barriers.*
- [26] *IEC 61375-2-3: Electronic Railway Equipment - Train Communication Network (TCN) - Part 2-3: TCN Communication Profil.*
- [27] *IEC 61375-3-4: Electronic Railway Equipment - Train Communication Network (TCN) - Part 3-4: Ethernet Consist Network (ECN).*

A.1 List of Figures

Figure 1 – Block diagram of a bi-mode fuel cell hybrid system (source: IEC 62864-1, modified).....	5
Figure 2 – Fuel Cell Hybrid PowerPack	6
Figure 3 Generic DC Train architecture	7
Figure 4 Generic AC Train architecture	7
Figure 5 FCHPP architecture.....	8
Figure 6 Fuel Cell System Block Diagram.....	10
Figure 7 Fuel Cell Cooling System Block Diagram.....	14
Figure 8 - HT Cooling System hydraulic interface.....	15
Figure 9 - LT Cooling System hydraulic interface	16
Figure 10 – Hydrogen Storage System Block Diagram	17
Figure 11 – Some examples of fixing clamp for fuel lines	19
Figure 12 – Double ferrule fitting.....	19
Figure 13 – Simplified P&ID.....	20
Figure 14 – WEH nozzle-receptacle for heavy-duty vehicles	21
Figure 15 – Communication options between vehicle and HRS. Source: CNH2	23
Figure 16 – Battery System Block Diagram	24
Figure 17 – HV DC/DC Converter Block Diagram	26
Figure 18 – DASEM Block Diagram	29

A.2 List of Tables

No se encuentran elementos de tabla de ilustraciones.